

winterhalter

Spare Parts List GS 28

Revised 10/04

Part No. 89001367

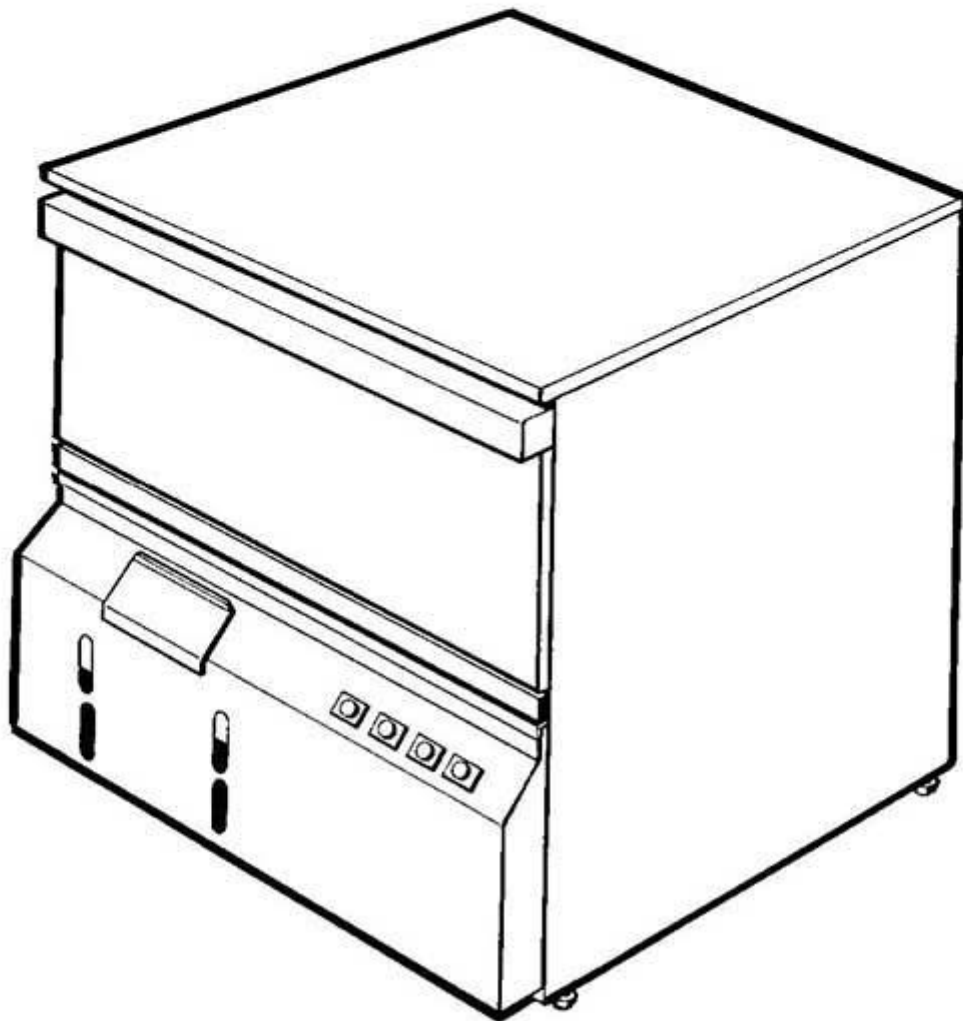

Summary

Water supply	Page 1 and 2
Water inlet and dosing	Page 3 and 4
Water drain and tank heating	Page 5 and 6
Wash system I	Page 7 and 8
Wash system II	Page 9 and 10
Rinsing I	Page 11 and 12
Rinsing II	Page 13 and 14
Door	Page 15 and 16
Sheathing, base frame and container	Page 17 and 18
Electrical parts I	Page 19 and 20
Electrical parts II	Page 21 and 22

Racks and accessories see separate list.

Parts that have the note " Part made to order only!" are not in stock. This parts are made specially for your order and have a delivery time. They are not returnable.

GS 28

Wasserzulauf
Water supply
Alimentation d'eau

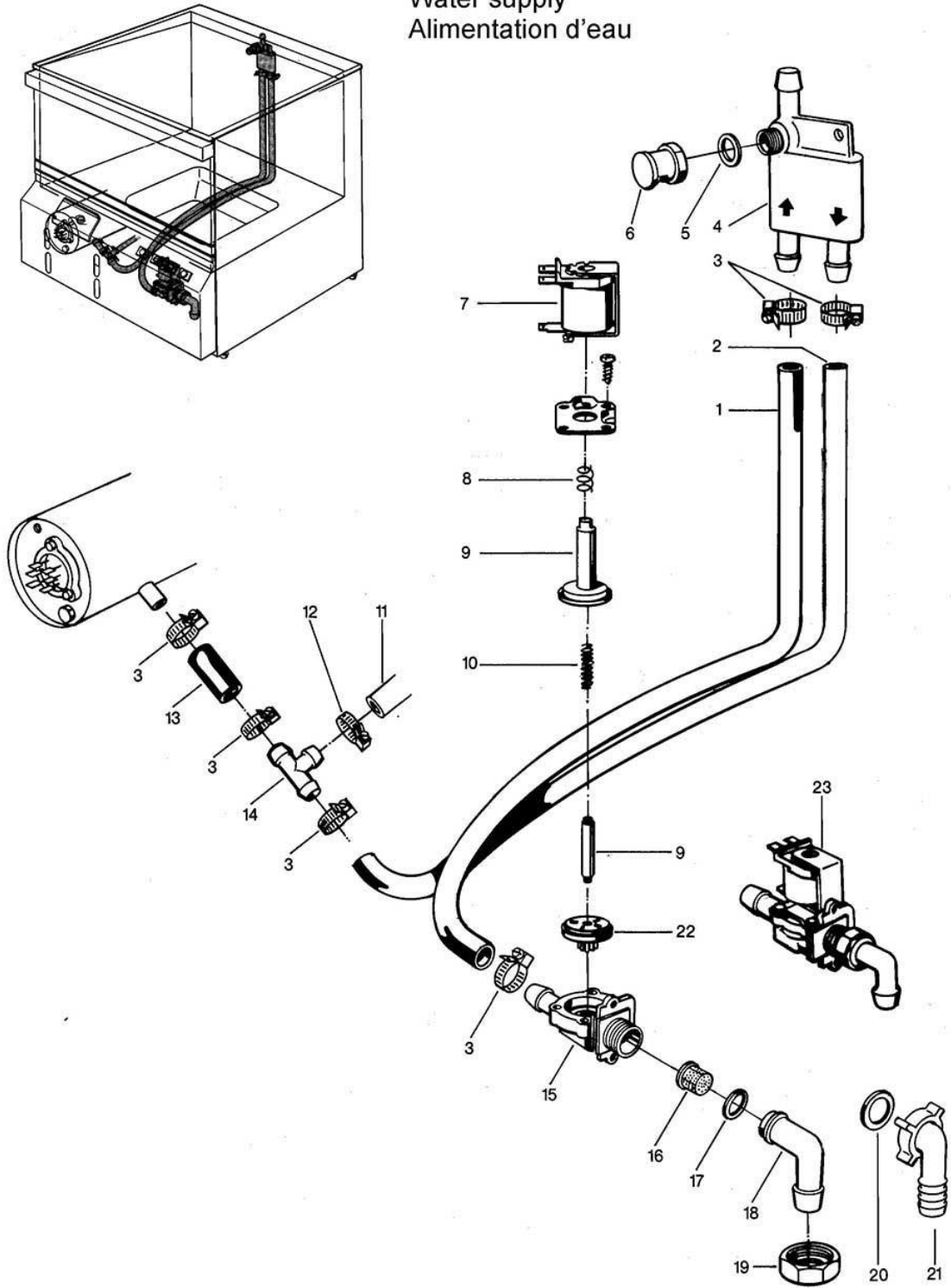

GS 28
Water supply

Pos.	Designation	Part no.	Notes
1	Shaped hose \varnothing 13 x 4 x 830	40 03 047	to adapt
2	Shaped hose \varnothing 13 x 4 x 790	40 03 047	to adapt
3	Hose clip \varnothing 14 - \varnothing 24	28 02 108	
4	Backflow restrictor "S"	35 01 194	
5	Fibre washer \varnothing 24 x \varnothing 17 x 2	27 09 009	
6	Vent cap BSP3/8"	35 01 207	
7	Magnetic coil 220/240 V 50/60 Hz		replaced by pos.23
8	Spring		
9	Plunger with bush		
10	Spring		
11	Hose \varnothing 5 x 3 x 240	40 01 024	per meter
12	Wire hose clamp \varnothing 8 - \varnothing 12	28 02 348	
13	Hose \varnothing 13,5 x 3,5 x 60	40 02 029	per meter
14	T-piece black	35 01 086	
15	Bottom part for single solenoid valve	31 06 180	
16	Fine dirt filter red	31 06 118	
17	Fibre washer \varnothing 24 x \varnothing 19,5 x 1,5	27 09 010	
18	Mediamat connection elbow	29 06 227	
19	Coupling nut BSP3/4"	29 07 203	
20	Fibre washer \varnothing 24 x \varnothing 14 x 2	27 01 023	
21	Angle connection BSP3/4"	60 002474	with fibre washer
22	Diaphragm		Replaced by Pos. 23
23	Solenoid valve 220 V 50 Hz	31 06 180	
n.p.	Boiler inlet cpl.	55 09 038	consist. of pos. 3, 11, 12, 13, 14
n.p.	Metal hose \varnothing 15 x 1500; G 3/4"	29 01 316	replaces pos. 17 - 21
n.p.	Seal \varnothing 24 x \varnothing 17 x 2	80 002241	for metal hose

GS 28

Wassereinlauf und Dosierung
Water inlet and dosing
Arrivée d'eau et dosage

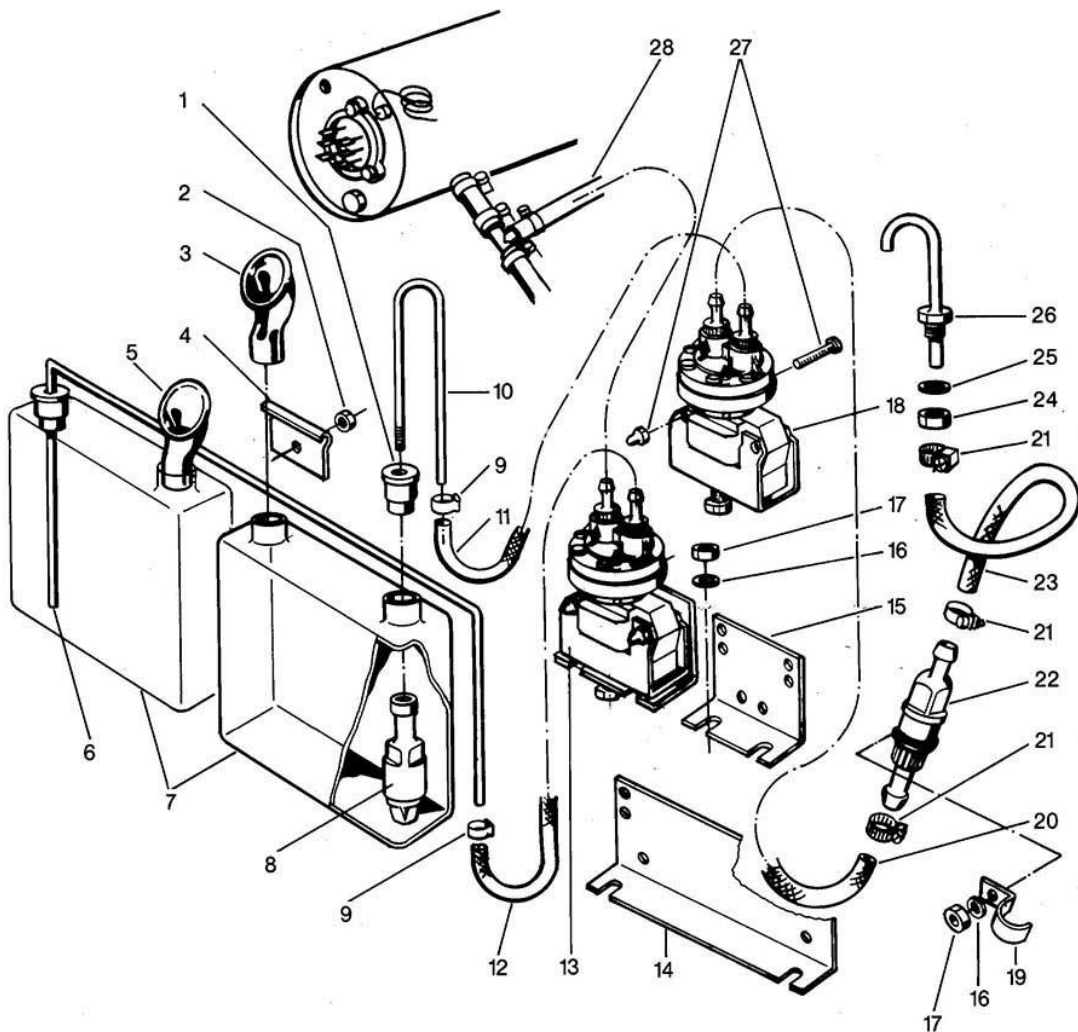
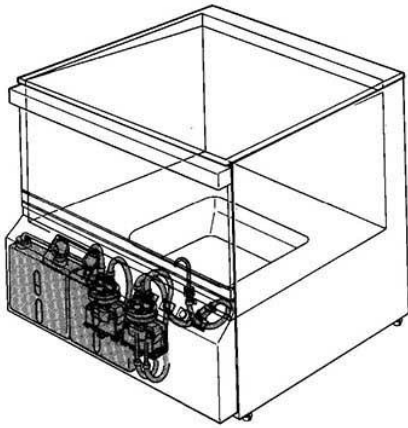

GS 28
Water inlet and dosing

Pos.	Designation	Part no.	Notes
1	Reducing bush	40 06 011	
2	Hexagon nut M 4	21 01 302	
3	Filling funnel grey	40 07 025	detergent
4	Thermostat clip	55 19 011	
5	Filling funnel blue	40 07 026	rinse aid
6	Connecting pipe	62000123	
7	Detergent container	35 02 020	
8	Ball valve - suction side		no more available
9	Wire hose clip \varnothing 8 - \varnothing 12	28 02 348	for 40 01 024
10	Suction pipe	28 14 327	
11	Hose piece \varnothing 6 x 3 x 420	40 01 024	per meter
12	Hose piece \varnothing 5 x 1,5 x 520	40 01 024	
13	Dispenser ELT 20	55 28 278	
14	Support for dispenser	62001069	from series 2842 1/90
15	Support for dispenser	60000314	until series 2481 12/89
16	Washer \varnothing 5,3	22 01 300	
17	Hexagon nut M 5	21 01 303	
18	Dispenser ELT 20	55 28 278	
19	Clamp	55 25 017	
20	Hose piece \varnothing 5 x 3 x 320	40 01 024	per meter
21	Wire hose clip \varnothing 8 - \varnothing 12	28 02 348	for 40 01 024
22	Ball valve - pressure side		no more available
23	Hose piece \varnothing 6 x 3 x 180	40 01 022	per meter
24	Hexagon nut M 10	21 02 306	
25	Fibre washer M 10	22 08 506	
26	Inlet elbow	55 25 062	Incl. Pos.24, 25
27	Fixing kit for dispenser ELT 10	55 25 029	
28	Hose piece \varnothing 5 x 1,5 x 240	40 01 024	per meter

GS 28

Wasserablauf und Tankheizung

Water drain and tank heating

Ecoulement d'eau et chauffage de la cuve

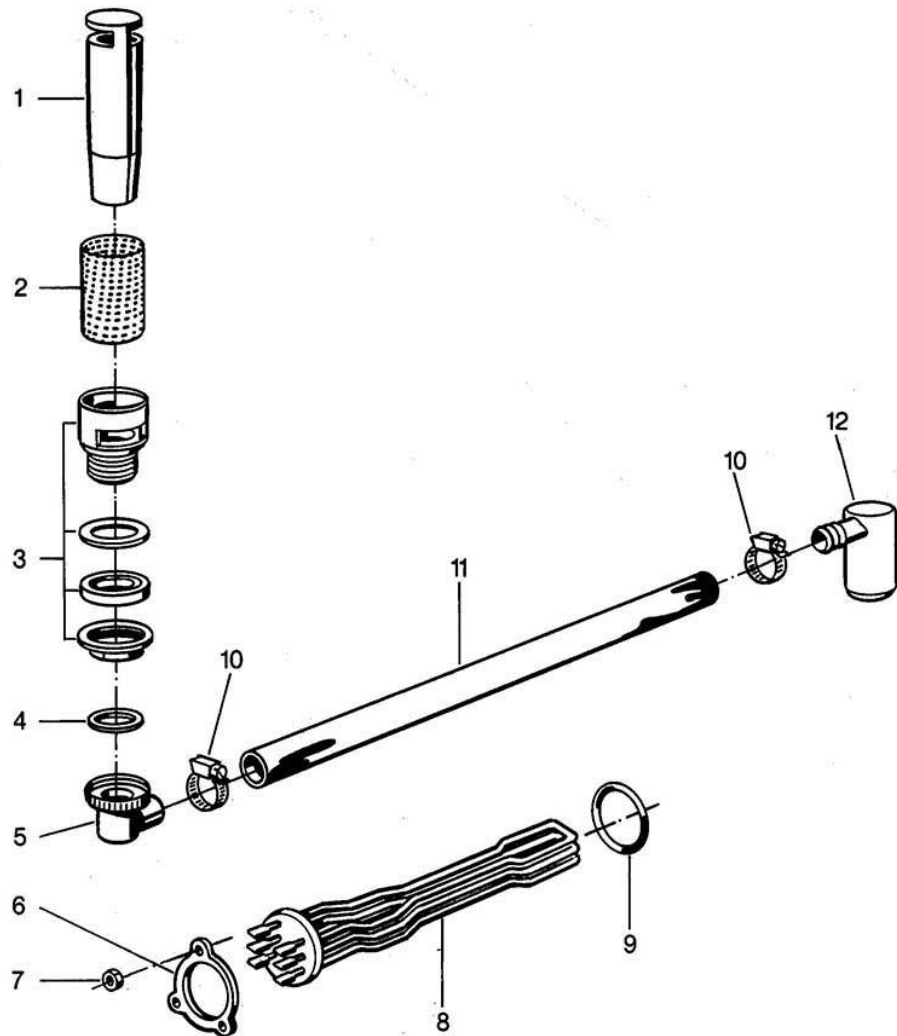
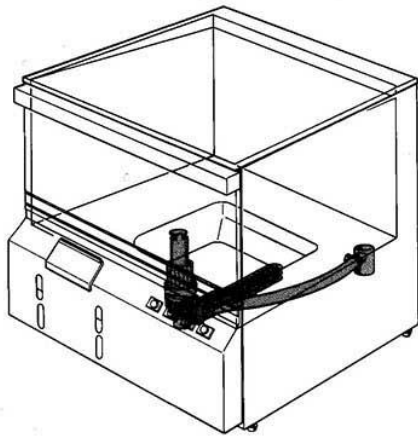

GS 28
Water drain and tank heating

Pos.	Designation	Part no.	Notes
1	Stand pipe 130 mm	62002648	
2	Stand pipe filter; 185 mm	29 04 229	adapt
3	Stand pipe bottom part	29 04 228	
n.p.	Drain strainer in pos. 3	29 04 507	
4	Fibre washer $\varnothing 39 \times \varnothing 32 \times 2$	27 02 001	
5	Drain outlet connection	29 04 247	
6	Clamping plate	01 17 003	
7	Hexagon nut M 5	21 01 303	
8	Heating element 3 kW 220/380 V	31 03 027	
n.p.	Heating element 3 kW 240/420 V	31 03 029	
9	O-ring $\varnothing 46 \times 6$	27 07 069	
10	Hose clip $\varnothing 24 - \varnothing 36$	28 02 111	
11	Hose piece $\varnothing 24 \times 4 \times 510$	40 03 033	per meter
12	Angled drain outlet	35 01 208	

GS 28

Waschsystem I
Wash system I
Système de lavage I

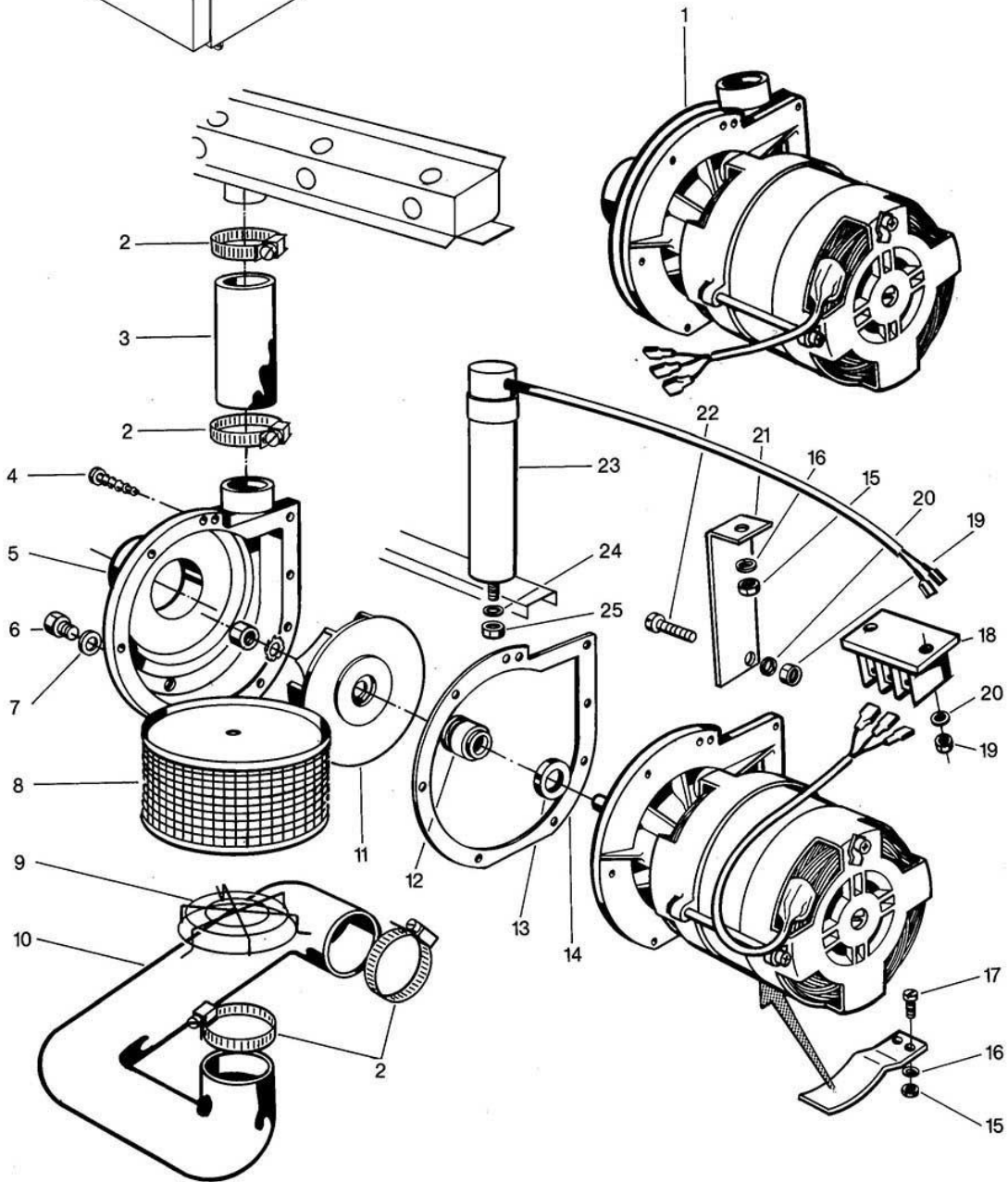
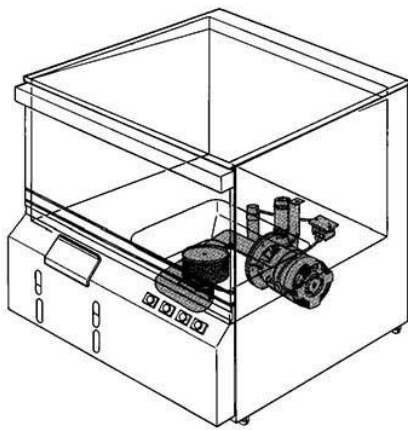

GS 28
Wash system

Pos.	Designation	Part no.	Notes
1	Pump 0,55 kW 230 V	31 02 276	incl. Pos. 23
n.p.	Pump 0,55 kW 200 V 50 Hz	31 02 319	incl. Pos. 23
n.p.	Pump 0,55 kW 200 V 60 H	31 02 320	incl. Pos. 23
n.p.	Pump 220 V, 60 Hz	31 02 070	incl. Pos. 23
2	Hose clip	28 02 110	
3	Hose piece DN38 x 4 x 75	40 02 014	per meter
4	Sheet metal screw 3,9 x 22	20 22 302	
5	Pump housing	31 02 200	
6	Hexagon screw M 8 x 15	20 01 302	
7	Fibre washer M 8	22 08 505	
8	Pump filter round	55 13 003	
9	Suction filter	55 13 113	
10	Rubber elbow	40 03 021	
11	Impeller 50 Hz	31 02 201	
n.p.	Hexagon nut M 6 (left-hand thread)	21 01 309	for fixing impeller
o.P.	Impeller 60 Hz	55 14 034	
n.p.	Tooth washer ø 6,4	23 01 004	
12	Sealing kit	80 002673	consist. of pos.12,13,14
13	Seating ring	80 00 2673	
14	Seal for housing	31 02 203	
15	Hexagon nut M 5	21 01 303	
16	Washer ø 5,3	22 01 300	
17	Pan head screw M 5 x 10	20 10 322	
18	Terminal block	31 09 011	
19	Hexagon nut M 4	21 01 302	
20	Spring washer B 4	23 03 304	
21	Pump supporting angle	62000071	
22	Pan head screw M 4 x 30	20 10 316	
23	Capacitor 12,5 µF	31 13 028	
24	Washer ø 8,4	22 01 303	
25	Hexagon nut M 8	21 01 305	

GS 28

Washsystem II
Wash system II
Système de lavage II

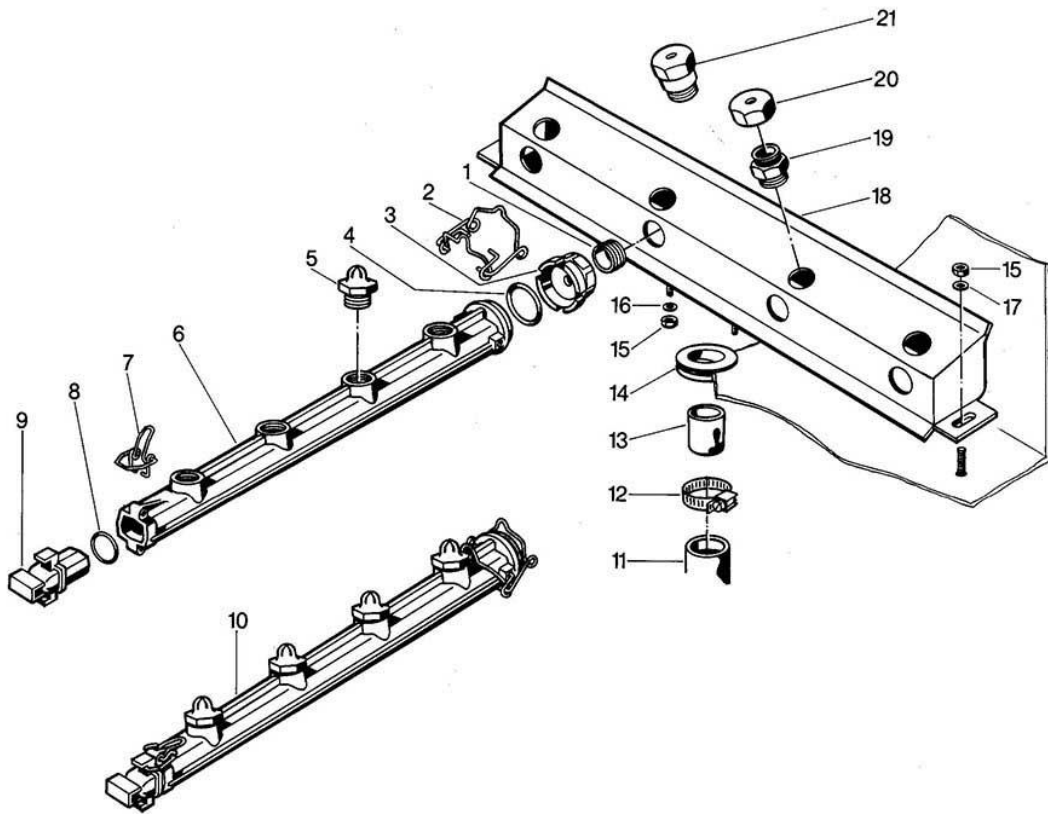
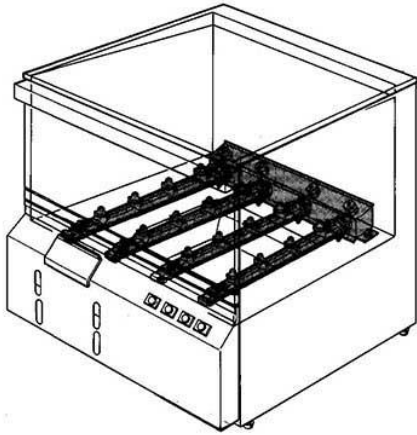

GS 28

Nachspülung I Rinsing I Rinçage I

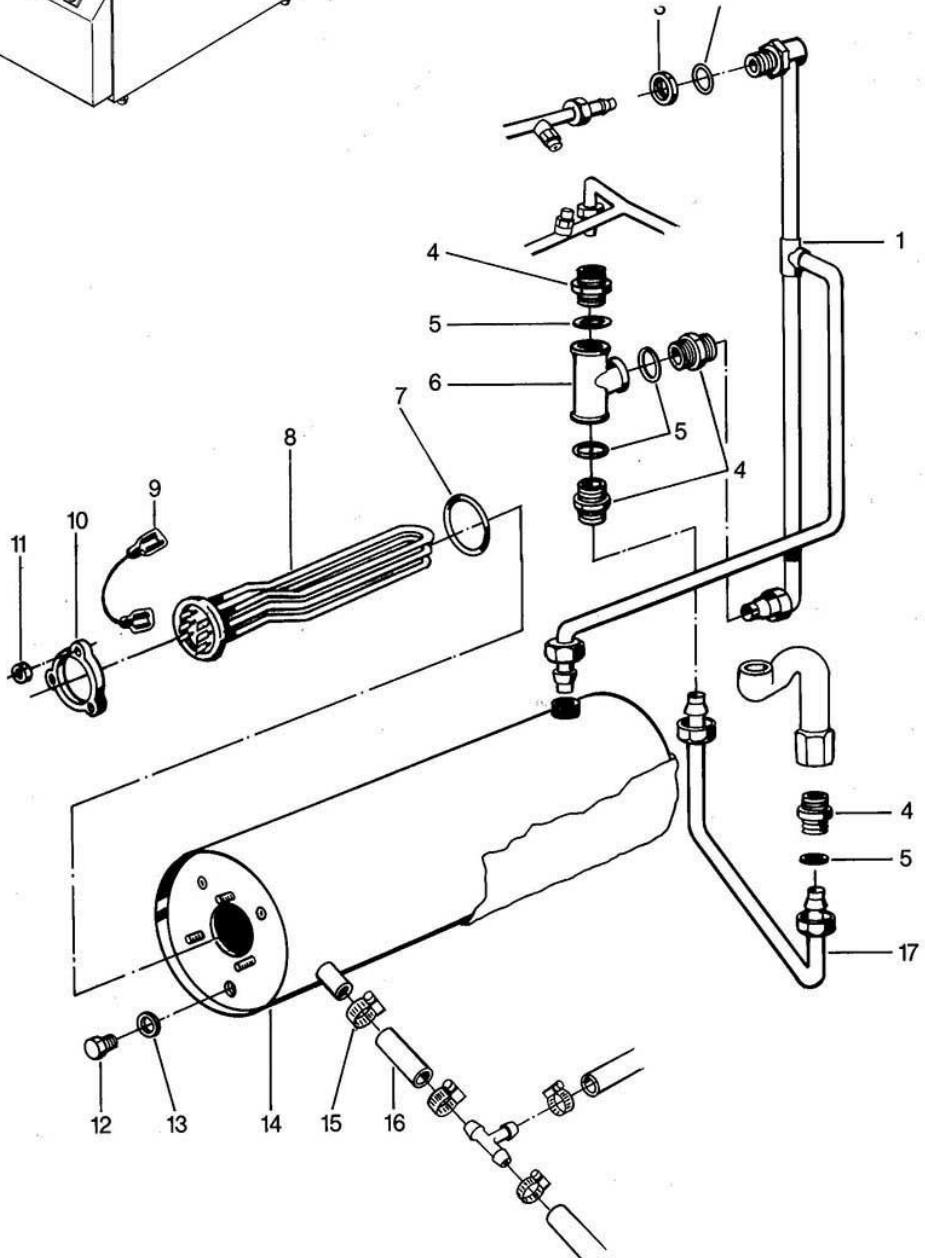
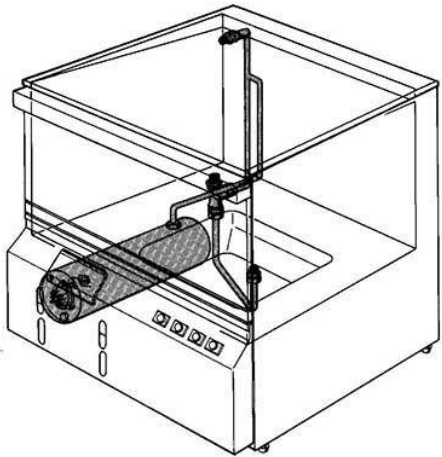

GS 28
Rinsing I

Pos.	Designation	Part no.	Notes
1	Rinse manifold cpl.	62001007	
2	Fibre washer \varnothing 24 x \varnothing 17 x 2	27 09 009	
3	Locking nut BSP3/8"	30 09 200	
4	Double nipple BSP1/2" x 30	70000459	
5	Fibre washer \varnothing 28 x 21 x 2	27 09 011	
6	T-piece BSP1/2"	30 04 100	
7	O-ring	27 07 069	
8	Heating element 220/380 V; 5 kW	31 03 030	
n.p.	Heating element 240/420 V; 5 kW	31 03 032	
9	Link wire	31 23 088	
10	Clamping plate	01 17 003	
11	Hexagon nut M 5	21 01 303	
12	Hexagon screw M 10 x 14	20 01 352	
13	Fibre washer \varnothing 18 x \varnothing 10 x 1,5	27 03 003	
14	Boiler	55 12 005	without heating element
15	Hose clip \varnothing 14 - \varnothing 24	28 02 108	
16	Hose piece \varnothing 13,5 x 3,5 x 60	40 02 029	per meter
17	Rinse connection long	55 11 040	with DVGW from 12/87
o.P.	Rinse connection short	62000506	without DVGW until 11/87

GS 28

Nachspülung II Rinsing II Rinçage II

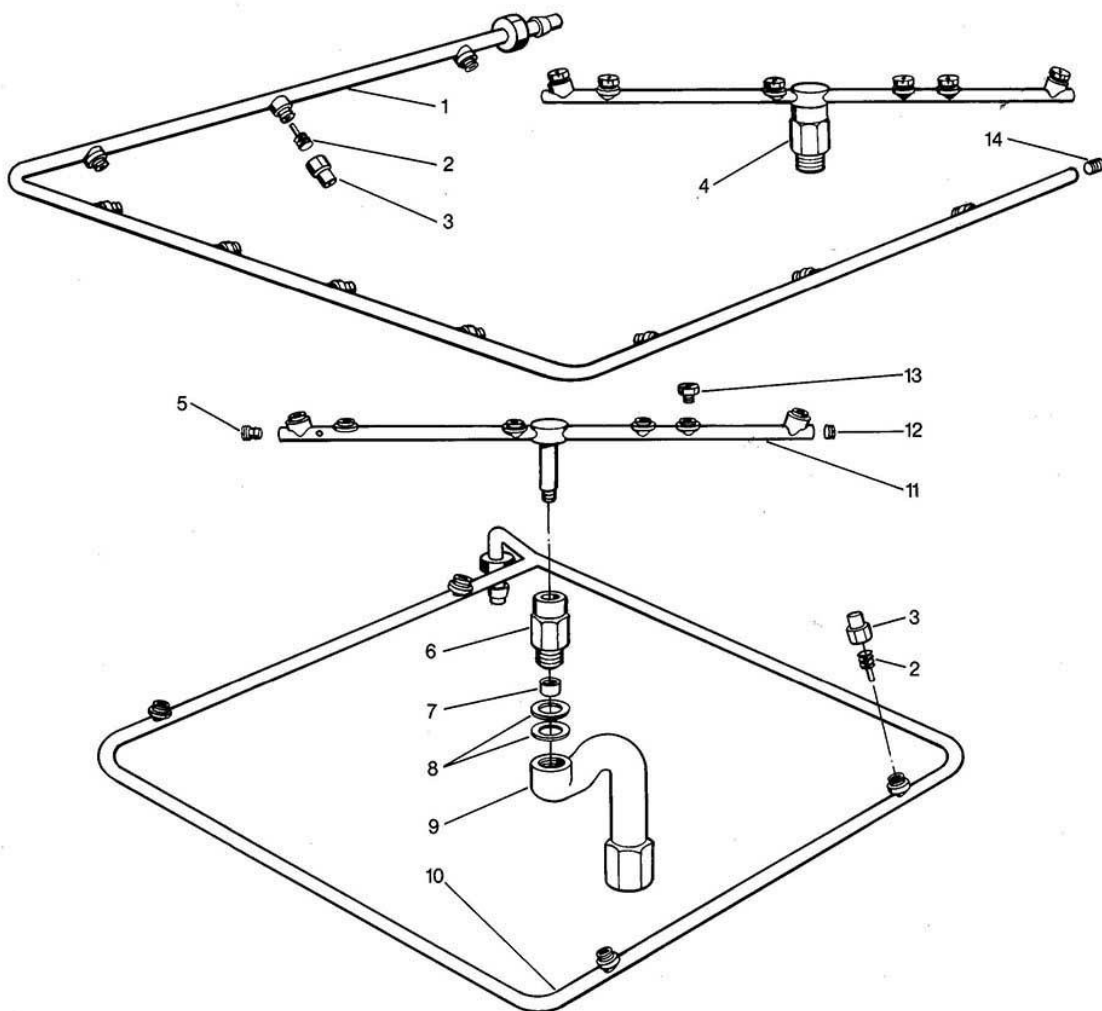
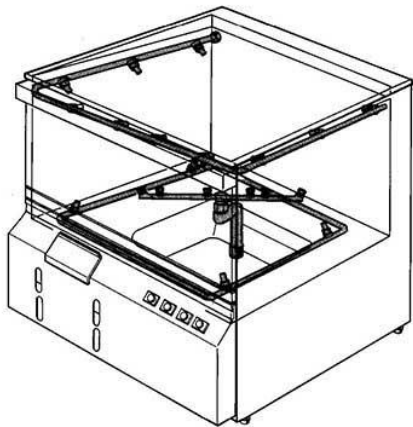

GS 28

Türe
Door
Porte

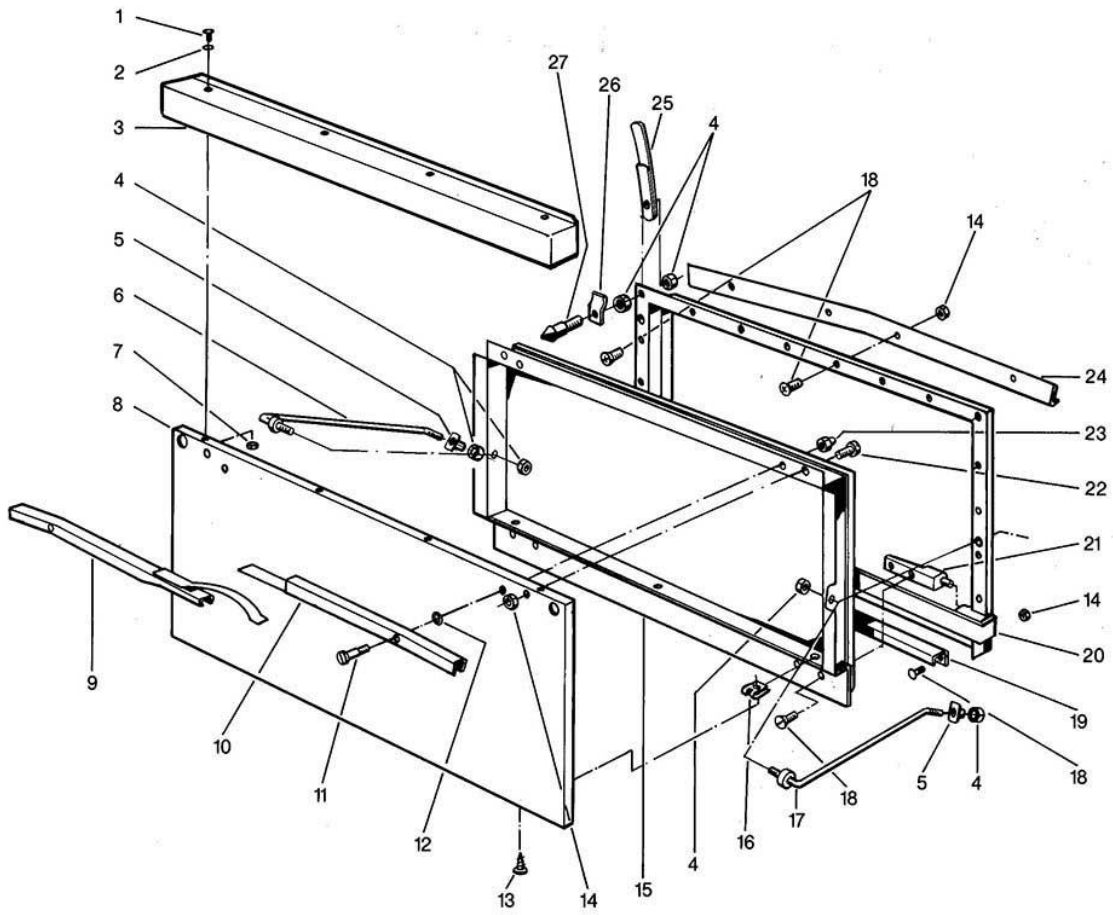
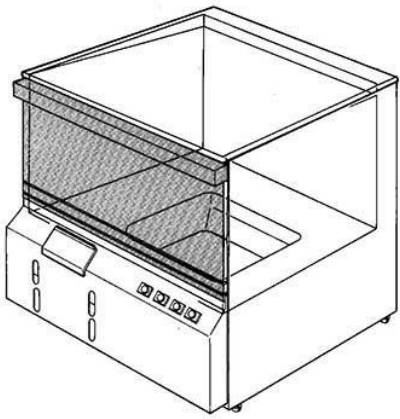

GS 28
Door

Pos.	Designation	Part no.	Notes
1	Lens head countersunk screw M 3 x 6	20 12 300	
2	Fibre washer M 3	22 08 501	
3	Door handle cpl.	55 15 033	
4	Hexagon nut M 5	21 05 302	self-locking
5	Welding nut M 5	21 06 329	
6	Door stay left cpl.	55 15 053	
7	Hexagon nut M 3 self-securing	21 05 303	
8	Door outer panel	55 15 014	
9	Door lock right cpl.	55 15 057	spring part
10	Door lock left cpl.	55 15 058	plate part
11	Cylinder screw M 4 x 26	20 19 300	
12	Washer ø 4,3	22 02 302	
13	Sheet metal screw B 3,9 x 16	20 20 300	
14	Hexagon nut M 4	21 01 302	
15	Door inner panel cpl.	55 15 015	
16	Sheet metal nut B 3,9	21 17 300	
17	Door stay right cpl.	55 15 054	
18	Lens head countersunk screw M 4 x 10	20 12 312	
19	Profile plate 595 mm long	62000109	
20	Door frame	35 01 050	
o.P.	Door frame	55 15 153	made of CNS
21	Door hinge with pin	02 30 009	
22	Pan head screw M 4 x 12	20 10 312	
23	Dome head nut M 4	21 10 302	
24	Drop plate 550 mm long	62000104	
25	Micro switch spring	55 28 502	
26	Door stop	62000100	
27	Door catch bolt ø 9,5 x 38,5	20 19 303	
n.p.	Door cpl. with cavity	80000451	for racks 500 x 500
n.p.	Welding bolt for door limit switch	24 01 308	
n.p.	Nylon washer M 4	22 08 502	
n.p.	Seal inside	55 15 036	

GS 28

Verkleidung, Untergestell und Behälter
Sheathing, base frame and container
Habillage, châssis et récipient

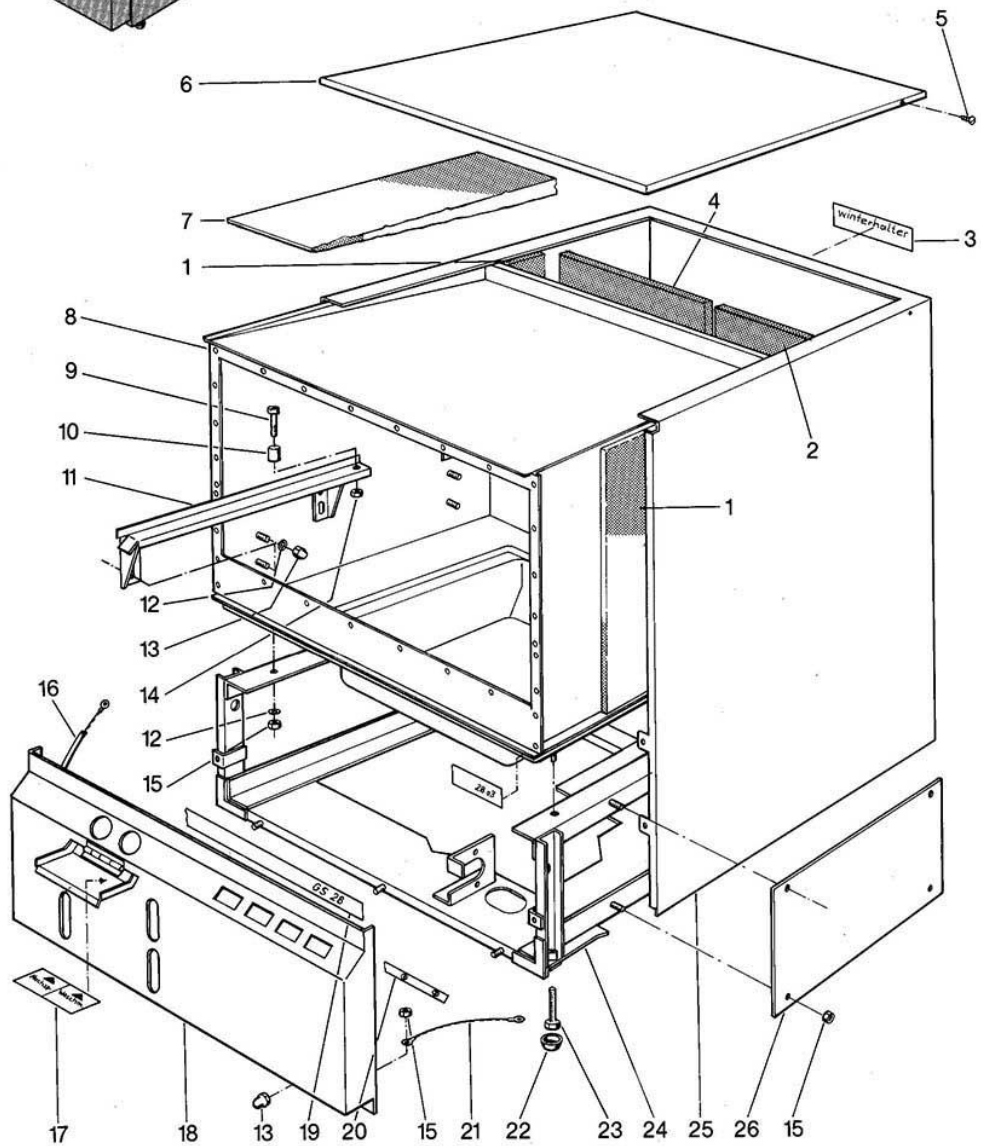
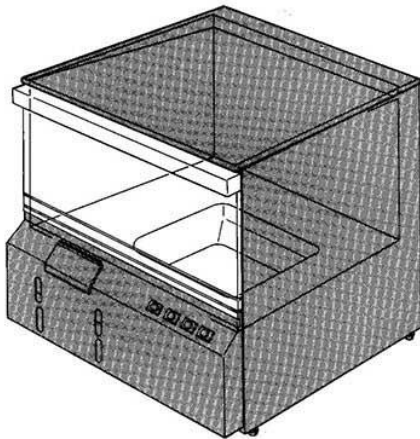

GS 28

Elektroteile I Electrical parts I Matériel électrique I

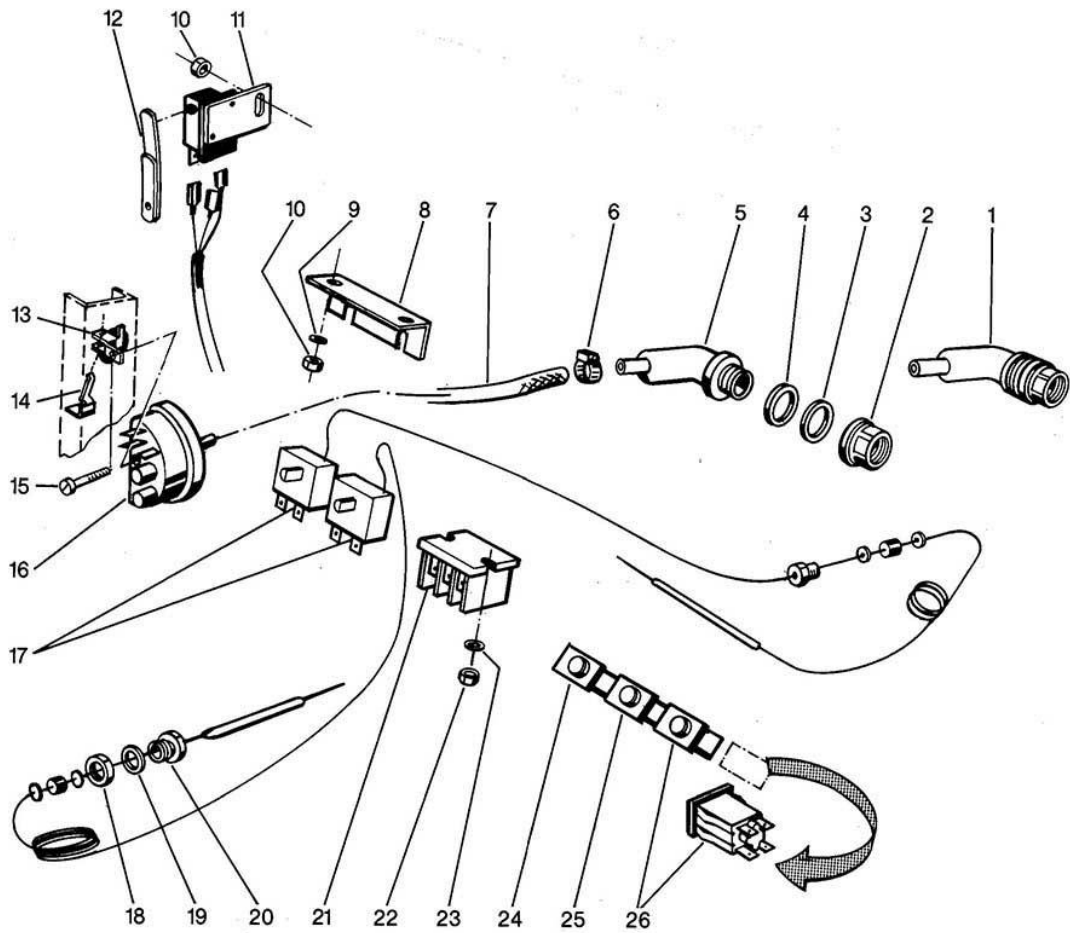
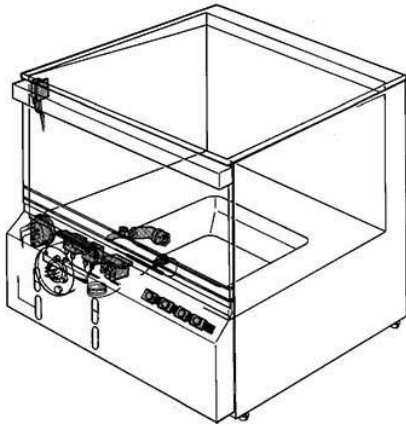

GS 28
Electrical parts I

Pos.	Designation	Part no.	Notes
1	Air chamber cpl.	55 04 024	consisting of pos. 2, 3, 4, 5
2	Bihexagonal nut	61 004893	
3	Supporting ring	62 002875	
4	O-Ring	27 07 066	
5	Air chamber BSP3/4"	35 01 073	only cpl. available pos. 1
6	Wire Hose clip \varnothing 8 - \varnothing 12	28 02 348	
7	Hose piece \varnothing 5 x 3 x 550	40 01 024	per meter
8	Thermostat support	62000035	
9	Washer \varnothing 5,3	22 02 203	
10	Hexagon nut M 5	21 01 303	
11	Micro switch cpl.	55 19 024	
12	Micro switch spring cpl.	55 28 502	
13	Fixing clip	31 26 024	for pressure switch
14	Retaining spring	31 26 016	
15	Screw for fixing clip	31 26 025	
16	Pressure switch white 70/50	31 26 033	
17	Thermostat 1750 lg.	31 25 013	for tank and boiler
18	Hexagon nut M 14 x 1	31 25 002	
19	Fibre washer \varnothing 22,5 x \varnothing 14,2 x 1,5	27 09 007	
20	Gland for thermostat M 14 x 1	31 25 001	
21	Terminal block threefold	31 09 011	
22	Hexagon nut M 4	21 01 302	
23	Spring washer B 4	23 03 304	
24	Pressure switch green	31 24 185	ON - OFF
25	Lamp white	31 08 116	control lamp
26	Pressure key button	31 24 130	programme 2 min.
n.p.	Pressure key button	31 24 153	programme 1 min.

GS 28

Elektroteile II Electrical parts II Matériel électrique II

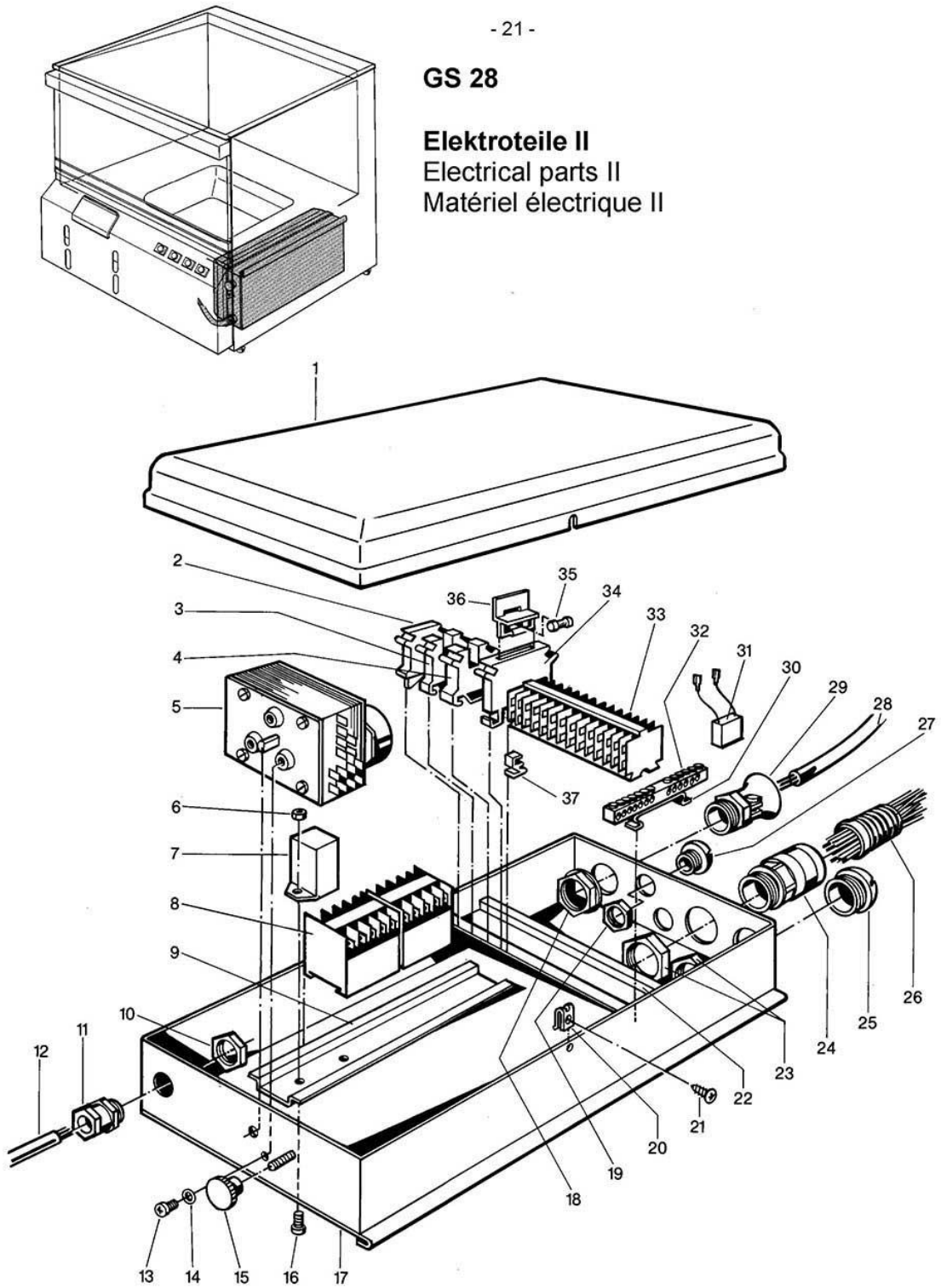

GS 28 Electrical parts II

Pos.	Designation	Part no.	Notes
1	Relay box cover	62001071	until series no. 2688 12/91
n.p.	Relay box cover	62001659	from series no. 2717 1/92
2	Terminal block grey	31 09 049	
3	Terminal block blue	31 09 050	
4	Earth conductor terminal USLKG	31 09 064	
5	Programme switch	31 05 119	
6	Hexagon nut M 3	21 01 301	
7	Mini relay 220 V	31 13 045	
8	Mini contactor 220 V 50 Hz	31 04 068	
n.p.	Mini contactor 220 V 60 Hz	31 04 070	
9	D/N rail 190 long	62000129	
10	Hexagon nut PG 11	31 10 045	
11	Cable gland PG 11	31 10 044	
12	Wiring loom	31 23 077	
13	Pan head screw M 4 x 8	20 10 309	
14	Tooth lock washer \varnothing 4,3	23 01 002	
15	Knurled nut M 6	21 12 004	
16	Cylinder screw M 3 x 8	20 10 004	
17	Contactor box bottom box	60000936	
18	Hexagon nut PG 16	30 10 110	
19	Hexagon nut PG 9	31 10 043	
20	Sheet metal nut B 3,9	21 17 301	
21	Sheet metal screw 3,9 x 13	20 20 310	
22	D/N rail 178,5 long	60000279	Part made to order only!
23	Hexagon nut PG 21	31 10 071	
24	Cable gland PG 21	31 10 070	
25	Blanking cap PG 21	31 10 027	
26	Wiring loom I		no more available
27	Blanking cap PG 9	31 10 021	
28	Mains cable	31 23 132	
29	Screw cable gland PG 16	31 10 049	
30	Catch spring for earth conductor terminal		no more available
31	RC member 0,27 μ F	60000990	w.receptacle and heat-shrinkable sleeve
32	Earth conductor terminal SZ-KLB 12	31 09 094	
33	Terminal 13-fach	55 19 070	
34	Terminal block UK-SI	31 09 063	
35	Fuse link 250 V 6,3 A	31 11 043	
36	Two-pin fuse holder	31 09 072	
37	Retaining clip	31 09 012	
n.p.	Time relay	31 04 117	for predosing
n.p.	Set predosing	55 28 129	with cable